



PRODUCT DATA & INSTALLATION

Bulletin T30-TTL-PDI-16
Part # 1087831

TTL Two-Way Low Profile Evaporators

High, Medium and Low Temperature Applications
-10°F (-23.3 °C) or Above Box Temperature



PRODUCT SUPPORT
 web: t-rp.com/ttl
 email: evaps@t-rp.com
 call: 1-844-893-3222 x520

scan:

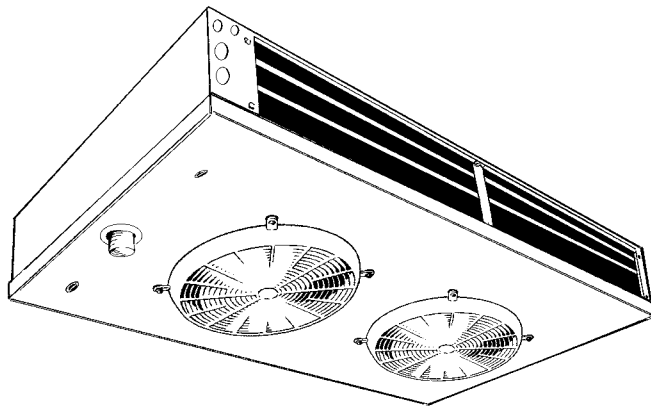

Air, Electric or Hot Gas Defrost (Reverse Cycle)



CONTENTS

	Page
Nomenclature.....	2
Features.....	2
Capacity Data (Imperial and <i>Metric</i>).....	3
Electrical Data.....	4 - 5
Wiring Diagrams.....	6 - 8
Dimensional Data.....	9 - 10
TXV Selection.....	11 - 12
Installation Instructions.....	13 - 14
Project Information.....	14
Product Support Resources: Service Parts, Troubleshooting, Warranty, etc.....	15
“As Built” Service Parts List.....	BACK

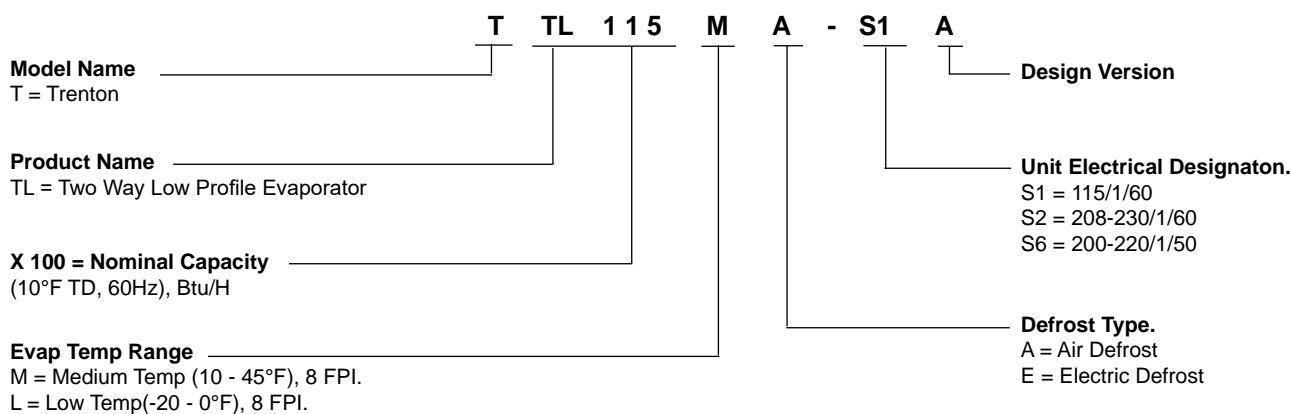
NOMENCLATURE



STANDARD FEATURES

- Compatible with Low GWP Refrigerants
- Low height compact size maximizes useable storage space
- Dual refrigeration coils and two-way air distribution reduces air velocities to minimize product dehydration
- Air enters through fan and discharges two ways out of each coil side
- Rugged heavy duty motor mount reduces vibration and noise
- Electric defrost models include factory installed defrost termination and fan delay thermostat
- NSF approved “flush to ceiling mount”
- Internally enhanced tube

AVAILABLE OPTIONS

- PSC Motors available on all models
- EC Motors available for Medium Temperature models 038, 060, 077 & 115 and Low Temperature models 033, 052, 066 & 099
- Additional options available, please contact factory

MEDIUM TEMPERATURE MODELS - CAPACITY *

Model TTL		010M	015M	020M	025M	032M	038M	060M	077M	115M	
Number of Fans		1	1	1	1	1	1	2	2	3	
Capacity BTUH (WATTS)	Evap Temp. 25°F (-4°C)	R407A	900	1380	1900	2380	3040	3600	5700	7300	10900
		R448A	(264)	(404)	(557)	(696)	(891)	(1058)	(1670)	(2144)	(3202)
		R407C	860	1305	1800	2250	2880	3420	5400	6900	10400
		R404A	(250)	(383)	(527)	(660)	(844)	(1003)	(1582)	(2031)	(3033)
		R507	950	1450	2000	2500	3200	3800	6000	7700	11500
		R22	(278)	(425)	(586)	(733)	(938)	(1114)	(1758)	(2257)	(3370)
	R134a	900	1380	1900	2380	3000	3600	5700	7300	10900	
		(264)	(404)	(557)	(696)	(891)	(1058)	(1670)	(2144)	(3202)	
	R134a	855	1305	1800	2250	2880	3420	5400	6930	10350	
		(250)	(383)	(527)	(660)	(844)	(1003)	(1582)	(2031)	(3033)	
Air Flow	CFM (L/s)	130 (61)	180 (85)	237 (112)	270 (127)	440 (208)	440 (208)	928 (438)	807 (381)	1242 (586)	
Refrigerant ** Charge R407A	Lbs (Kg)	0.4 (0.2)	0.5 (0.2)	0.7 (0.3)	0.8 (0.4)	0.9 (0.4)	1.2 (0.5)	1.4 (0.6)	2.3 (1.0)	3.4 (1.5)	

LOW TEMPERATURE MODELS - CAPACITY *

Model TTL		009L	013L	017L	021L	028L	033L	052L	066L	099L	
Number of Fans		1	1	1	1	1	1	2	2	3	
Capacity BTUH (WATTS)	Evap Temp. -20°F (-28.9°C)	R407A	810	1190	1620	2000	2660	3100	4900	6300	9400
		R448A	(237)	(348)	(473)	(584)	(780)	(919)	(1448)	(1837)	(2756)
		R407C	770	1125	1530	1890	2520	2970	4700	6000	8900
		R404A	(224)	(329)	(448)	(554)	(739)	(870)	(1372)	(1741)	(2611)
		R507	850	1250	1700	2100	2800	3300	5200	6600	9900
		R22	(249)	(366)	(498)	(615)	(821)	(967)	(1524)	(1934)	(2901)
	R134a	810	1190	1620	2000	2700	3100	4900	6300	9400	
		(237)	(348)	(473)	(584)	(780)	(919)	(1448)	(1837)	(2756)	
	R134a	765	1125	1530	1890	2520	2970	4680	5940	8910	
		(224)	(329)	(448)	(554)	(739)	(870)	(1372)	(1741)	(2611)	
Air Flow	CFM (L/s)	130 (61)	180 (85)	237 (112)	270 (127)	440 (208)	440 (208)	928 (438)	807 (381)	1242 (586)	
Refrigerant ** Charge R407A	Lbs (Kg)	0.4 (0.2)	0.5 (0.2)	0.7 (0.3)	0.8 (0.4)	0.9 (0.4)	1.2 (0.5)	1.4 (0.6)	2.3 (1.0)	3.4 (1.5)	

* Derate capacity by 5% when using EC Motors

Capacities rated using 10°F (5.6°C) TD & 100°F (38°C) liquid temperature.

Capacities at other TD within a range of 8 to 15 °F (4.4 to 8.3°C) are directly proportional to TD, or use formula: Capacity = Rated capacity ÷ 10 x TD.

For capacities at TD outside of range 8 to 15 °F (4.4 to 8.3°C), or liquid temperature lower than 75°F (24°), consult factory.

Capacities for R448A, R407A and R407C are based on mean temperature. Mean temperature is the average temperature between the saturated suction temperature and the temperature feeding the evaporator. For dew point ratings, consult factory.

For R449A, use R448A data.

* CAPACITY CORRECTION FACTORS FOR LOW TEMPERATURE UNITS

SATURATED SUCTION TEMPERATURE °F (°C)	0 (-17.8)	-10 (23.3)	-20 (-28.9)
FACTOR	1.06	1.03	1.0

** REFRIGERANT CHARGE CONVERSION FACTORS

R448A	R407C	R404A	R507	R22	R134a
0.96	0.99	0.92	0.93	1.02	1.03

NO CORRECTION FACTOR REQUIRED FOR MEDIUM TEMP. UNITS

AIR DEFROST

MODEL TTL	No. of FANS	FAN MOTOR(S) - SHADED POLE (STANDARD)				FAN MOTOR(S)- PSC (OPTIONAL)				FAN MOTOR(S)- EC (OPTIONAL)			
		TOTAL MOTOR FLA	M.C.A.	M.O.P	WATTS	TOTAL MOTOR FLA	M.C.A.	M.O.P	WATTS	TOTAL MOTOR FLA	M.C.A.	M.O.P	WATTS
010MA-S1A	1	1.2	1.5	15	70	0.65	0.81	15	60	-	-	-	-
015MA-S1A	1	1.2	1.5	15	70	0.65	0.81	15	60	-	-	-	-
020MA-S1A	1	1.2	1.5	15	70	0.65	0.81	15	60	-	-	-	-
025MA-S1A	1	1.2	1.5	15	70	0.65	0.81	15	60	-	-	-	-
032MA-S1A	1	1.2	1.5	15	70	0.65	0.81	15	60	0.60	0.75	15	30
038MA-S1A	1	1.2	1.5	15	70	0.65	0.81	15	60	0.60	0.75	15	30
060MA-S1A	2	2.4	2.7	15	140	1.30	1.46	15	120	1.20	1.35	15	60
077MA-S1A	2	2.4	2.7	15	140	1.30	1.46	15	120	1.20	1.35	15	60
115MA-S1A	3	3.6	3.9	15	210	1.95	2.11	15	180	1.80	1.95	15	90

ELECTRIC DEFROST

MODEL TTL	No. of FANS	FAN MOTOR(S) - SHADED POLE (STANDARD)				FAN MOTOR(S)- PSC (OPTIONAL)				FAN MOTOR(S)- EC (OPTIONAL)				DEFROST HEATERS			
		TOTAL MOTOR FLA	M.C.A.	M.O.P	WATTS	TOTAL MOTOR FLA	M.C.A.	M.O.P	WATTS	TOTAL MOTOR FLA	M.C.A.	M.O.P	WATTS	TOTAL WATTS	TOTAL AMPS	M.C.A.	M.O.P
010ME-S1A	1	1.2	1.5	15	70	0.65	0.81	15	60	-	-	-	-	206	1.8	2.2	15
015ME-S1A	1	1.2	1.5	15	70	0.65	0.81	15	60	-	-	-	-	530	4.6	5.8	15
020ME-S1A	1	1.2	1.5	15	70	0.65	0.81	15	60	-	-	-	-	530	4.6	5.8	15
025ME-S1A	1	1.2	1.5	15	70	0.65	0.81	15	60	-	-	-	-	530	4.6	5.8	15
032ME-S1A	1	1.2	1.5	15	70	0.65	0.81	15	60	0.60	0.75	15	30	750	6.5	8.2	15
038ME-S1A	1	1.2	1.5	15	70	0.65	0.81	15	60	0.60	0.75	15	30	750	6.5	8.2	15
060ME-S1A	2	2.4	2.7	15	140	1.30	1.46	15	120	1.20	1.35	15	60	1100	9.6	12.0	15
077ME-S1A	2	2.4	2.7	15	140	1.30	1.46	15	120	1.20	1.35	15	60	1540	13.4	16.8	20
115ME-S1A	3	3.6	3.9	15	210	1.95	2.11	15	180	1.80	1.95	15	90	2270	19.7	24.6	25
009LE-S1A	1	1.2	1.5	15	70	0.65	0.81	15	60	-	-	-	-	206	1.8	2.2	15
013LE-S1A	1	1.2	1.5	15	70	0.65	0.81	15	60	-	-	-	-	530	4.6	5.8	15
017LE-S1A	1	1.2	1.5	15	70	0.65	0.81	15	60	-	-	-	-	530	4.6	5.8	15
021LE-S1A	1	1.2	1.5	15	70	0.65	0.81	15	60	-	-	-	-	530	4.6	5.8	15
028LE-S1A	1	1.2	1.5	15	70	0.65	0.81	15	60	0.60	0.75	15	30	750	6.5	8.2	15
033LE-S1A	1	1.2	1.5	15	70	0.65	0.81	15	60	0.60	0.75	15	30	750	6.5	8.2	15
052LE-S1A	2	2.4	2.7	15	140	1.30	1.46	15	120	1.20	1.35	15	60	1100	9.6	12.0	15
066LE-S1A	2	2.4	2.7	15	140	1.30	1.46	15	120	1.20	1.35	15	60	1540	13.4	16.8	20
099LE-S1A	3	3.6	3.9	15	210	1.95	2.11	15	180	1.80	1.95	15	90	2270	19.7	24.6	25

AIR DEFROST

MODEL TTL	No. of FANS	FAN MOTOR(S) - SHADED POLE(STANDARD)				FAN MOTOR(S)- PSC (OPTIONAL)				FAN MOTOR(S)- EC (OPTIONAL)			
		TOTAL MOTOR FLA	M.C.A.	M.O.P	WATTS	TOTAL MOTOR FLA	M.C.A.	M.O.P	WATTS	TOTAL MOTOR FLA	M.C.A.	M.O.P	WATTS
010MA-S2A	1	0.7	0.9	15	60	0.24	0.30	15	50	-	-	-	-
015MA-S2A	1	0.7	0.9	15	60	0.24	0.30	15	50	-	-	-	-
020MA-S2A	1	0.7	0.9	15	60	0.24	0.30	15	50	-	-	-	-
025MA-S2A	1	0.7	0.9	15	60	0.24	0.30	15	50	-	-	-	-
032MA-S2A	1	0.7	0.9	15	60	0.24	0.30	15	50	0.30	0.40	15	30
038MA-S2A	1	0.7	0.9	15	60	0.24	0.30	15	50	0.30	0.40	15	30
060MA-S2A	2	1.4	1.6	15	120	0.48	0.54	15	100	0.60	0.70	15	60
077MA-S2A	2	1.4	1.6	15	120	0.48	0.54	15	100	0.60	0.70	15	60
115MA-S2A	3	2.1	2.3	15	180	0.72	0.78	15	150	0.90	1.00	15	90

ELECTRIC DEFROST

MODEL TTL	No. of FANS	FAN MOTOR(S) - SHADED POLE(STANDARD)				FAN MOTOR(S)- PSC (OPTIONAL)				FAN MOTOR(S)- EC (OPTIONAL)				DEFROST HEATERS			
		TOTAL MOTOR FLA	M.C.A.	M.O.P	WATTS	TOTAL MOTOR FLA	M.C.A.	M.O.P	WATTS	TOTAL MOTOR FLA	M.C.A.	M.O.P	WATTS	TOTAL WATTS	TOTAL AMPS	M.C.A.	M.O.P
010ME-S2A	1	0.7	0.9	15	60	0.24	0.30	15	50	-	-	-	-	206	0.9	1.1	15
015ME-S2A	1	0.7	0.9	15	60	0.24	0.30	15	50	-	-	-	-	530	2.3	2.9	15
020ME-S2A	1	0.7	0.9	15	60	0.24	0.30	15	50	-	-	-	-	530	2.3	2.9	15
025ME-S2A	1	0.7	0.9	15	60	0.24	0.30	15	50	-	-	-	-	530	2.3	2.9	15
032ME-S2A	1	0.7	0.9	15	60	0.24	0.30	15	50	0.30	0.40	15	30	750	3.3	4.1	15
038ME-S2A	1	0.7	0.9	15	60	0.24	0.30	15	50	0.30	0.40	15	30	750	3.3	4.1	15
060ME-S2A	2	1.4	1.6	15	120	0.48	0.54	15	100	0.60	0.70	15	60	1100	4.8	6.0	15
077ME-S2A	2	1.4	1.6	15	120	0.48	0.54	15	100	0.60	0.70	15	60	1540	6.7	8.4	15
115ME-S2A	3	2.1	2.3	15	180	0.72	0.78	15	150	0.90	1.00	15	90	2270	9.9	12.4	15
009LE-S2A	1	0.7	0.9	15	60	0.24	0.30	15	50	-	-	-	-	206	0.9	1.1	15
013LE-S2A	1	0.7	0.9	15	60	0.24	0.30	15	50	-	-	-	-	530	2.3	2.9	15
017LE-S2A	1	0.7	0.9	15	60	0.24	0.30	15	50	-	-	-	-	530	2.3	2.9	15
021LE-S2A	1	0.7	0.9	15	60	0.24	0.30	15	50	-	-	-	-	530	2.3	2.9	15
028LE-S2A	1	0.7	0.9	15	60	0.24	0.30	15	50	0.30	0.40	15	30	750	3.3	4.1	15
033LE-S2A	1	0.7	0.9	15	60	0.24	0.30	15	50	0.30	0.40	15	30	750	3.3	4.1	15
052LE-S2A	2	1.4	1.6	15	120	0.48	0.54	15	100	0.60	0.70	15	60	1100	4.8	6.0	15
066LE-S2A	2	1.4	1.6	15	120	0.48	0.54	15	100	0.60	0.70	15	60	1540	6.7	8.4	15
099LE-S2A	3	2.1	2.3	15	180	0.72	0.78	15	150	0.90	1.00	15	90	2270	9.9	12.4	15

WIRING DIAGRAM AIR DEFROST - ALL VOLTAGES

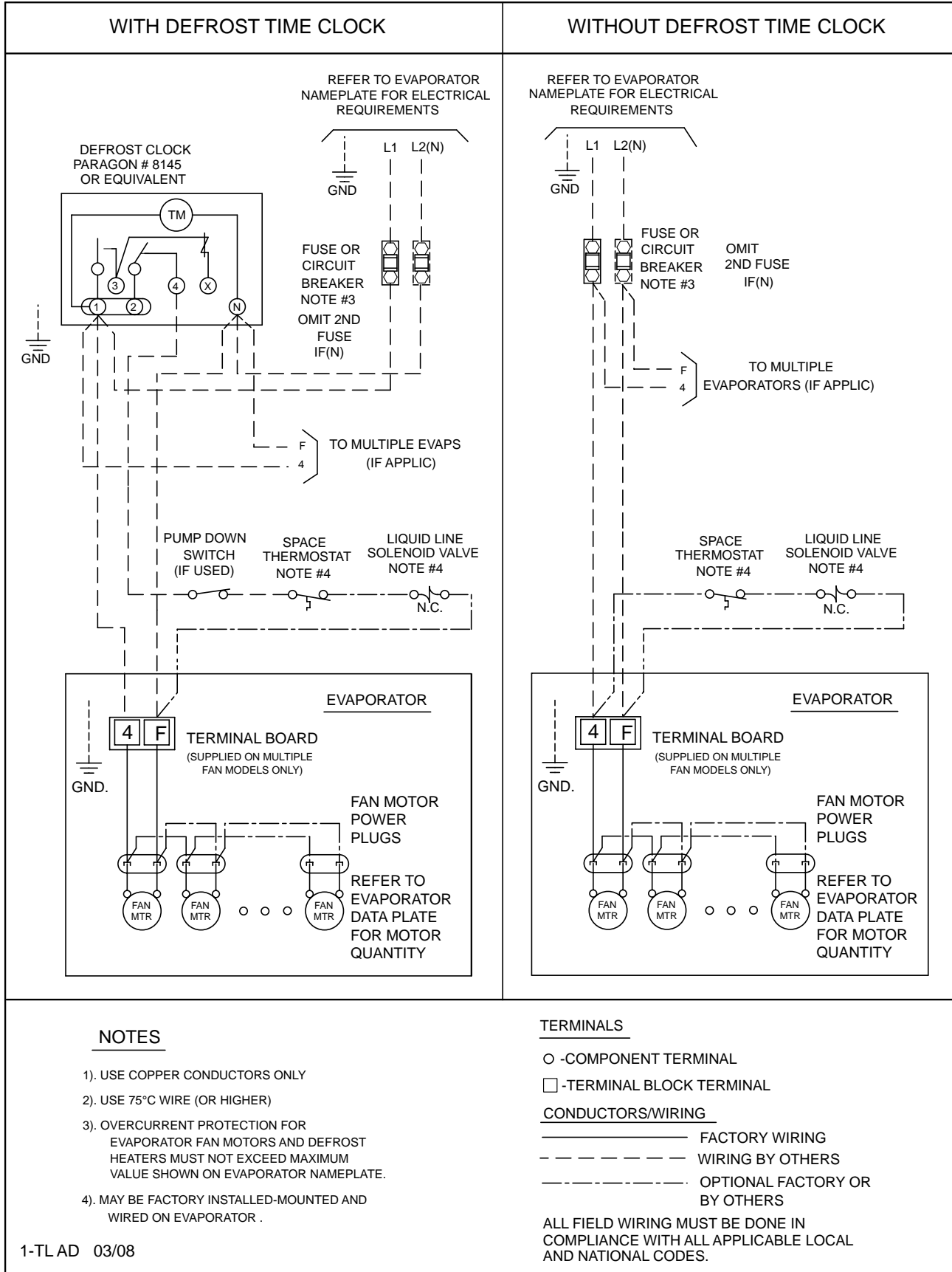

WIRING DIAGRAM ELECTRIC DEFROST - 115V

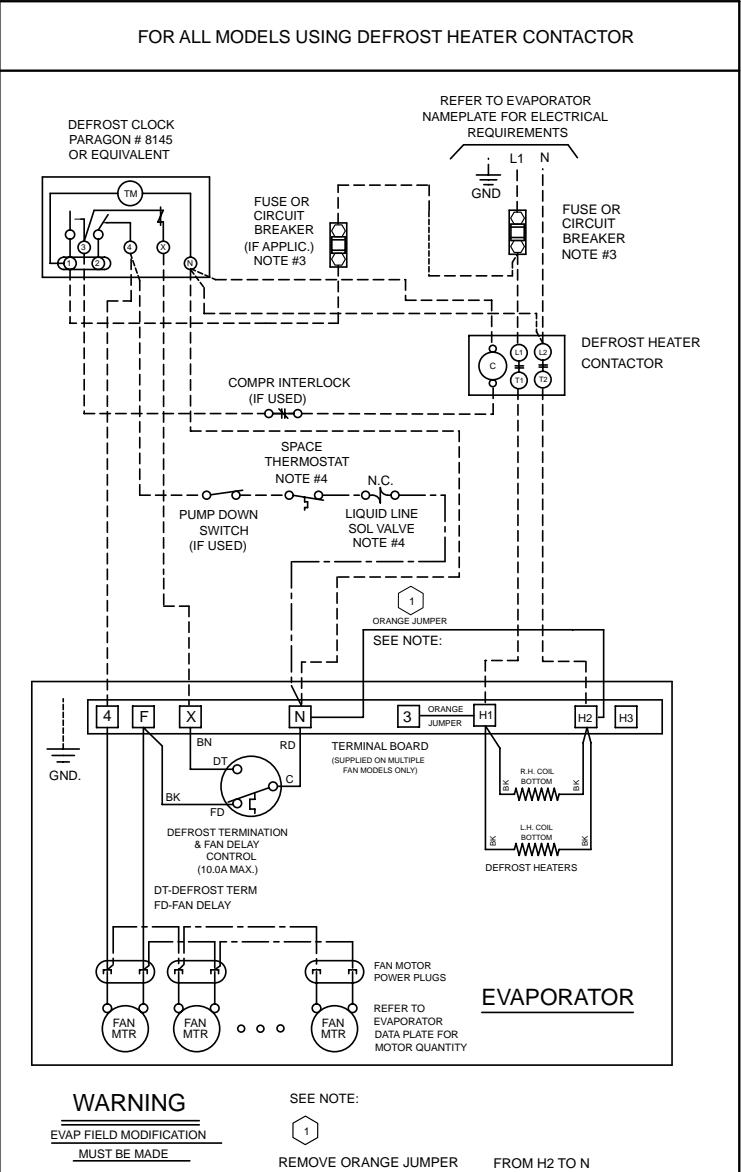
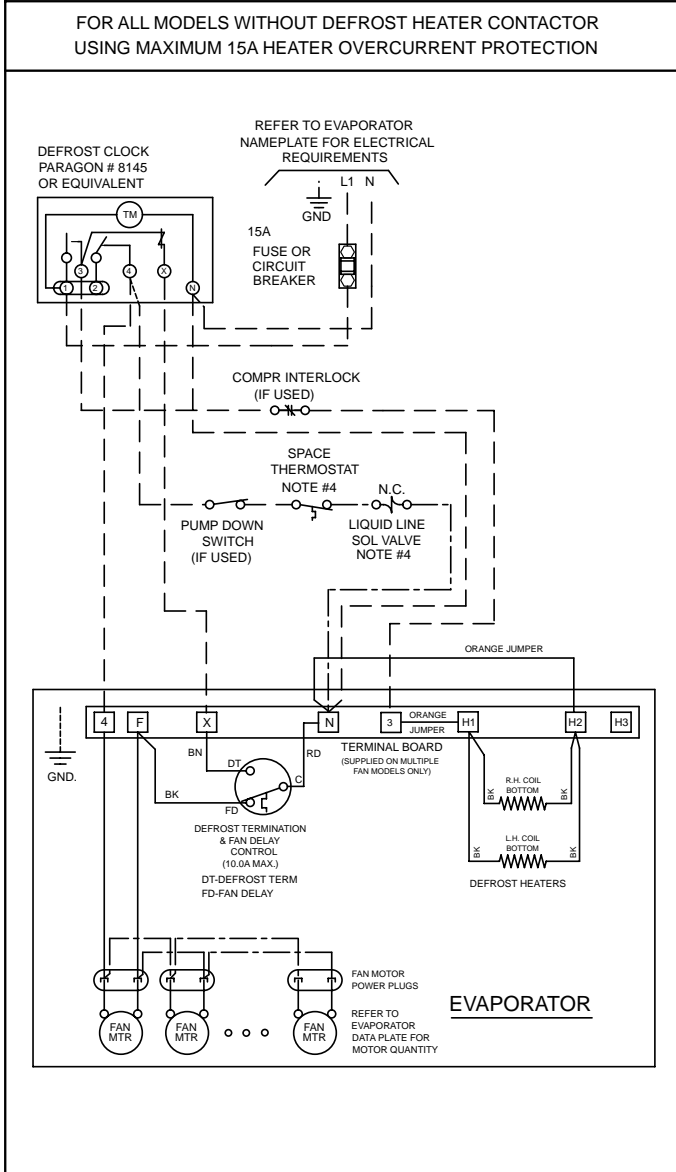

NOTES

- 1). USE COPPER CONDUCTORS ONLY
- 2). USE 75°C WIRE (OR HIGHER)
- 3). OVERCURRENT PROTECTION FOR EVAPORATOR FAN MOTORS AND DEFROST HEATERS MUST NOT EXCEED MAXIMUM VALUE SHOWN ON EVAPORATOR NAMEPLATE.
- 4.) MAY BE FACTORY INSTALLED-MOUNTED AND WIRED ON EVAPORATOR

TERMINALS

- -COMPONENT TERMINAL
- -TERMINAL BLOCK TERMINAL

CONDUCTORS/WIRING

- FACTORY WIRING
- - - - - WIRING BY OTHERS
- OPTIONAL FACTORY OR BY OTHERS

ALL FIELD WIRING MUST BE DONE IN COMPLIANCE WITH ALL APPLICABLE LOCAL AND NATIONAL CODES.

WIRING DIAGRAM ELECTRIC DEFROST - 230V

FOR ALL MODELS WITHOUT DEFROST HEATER CONTACTOR
USING MAXIMUM 15A HEATER OVERCURRENT PROTECTION

FOR ALL MODELS USING DEFROST HEATER CONTACTOR

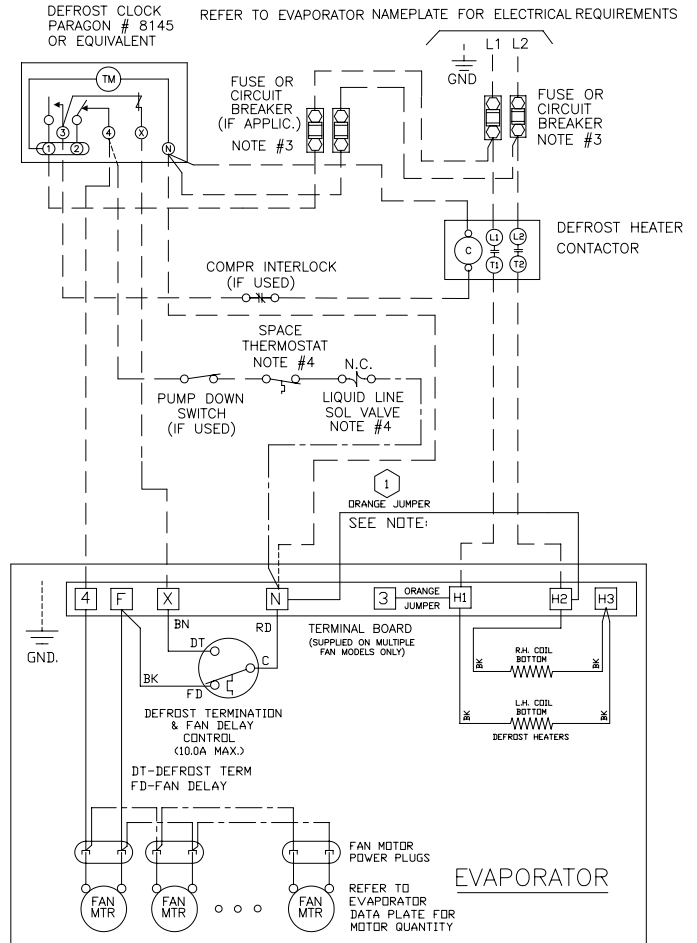
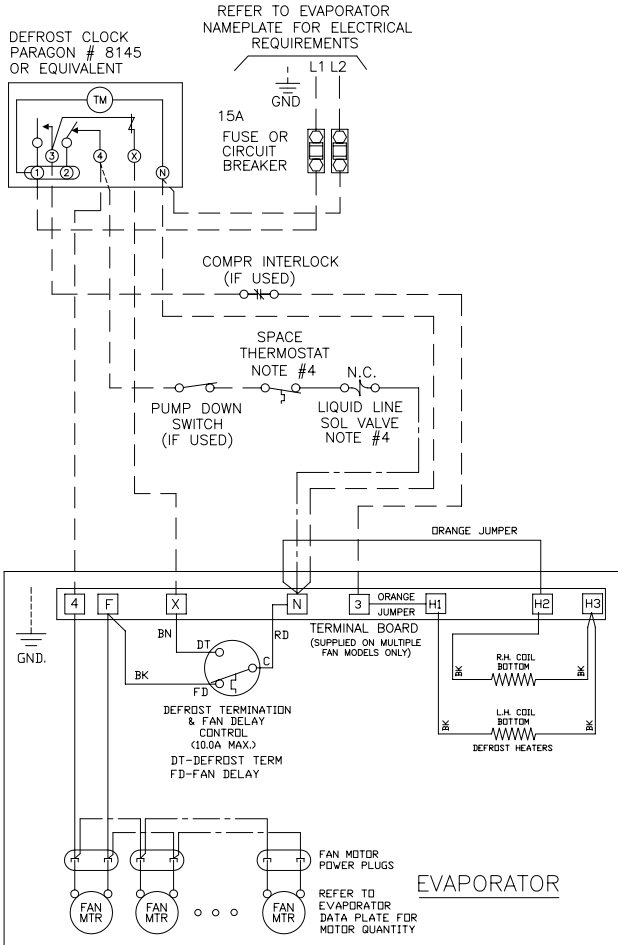

WARNING SEE NOTE #1
EVAP FIELD MODIFICATION MUST BE MADE REMOVE ORANGE JUMPER FROM H2 TO N

NOTES

- 1.) USE COPPER CONDUCTORS ONLY
- 2.) USE 75°C WIRE (OR HIGHER)
- 3.) OVERCURRENT PROTECTION FOR EVAPORATOR FAN MOTORS AND DEFROST HEATERS MUST NOT EXCEED MAXIMUM VALUE SHOWN ON EVAPORATOR NAMEPLATE.
- 4.) MAY BE FACTORY INSTALLED-MOUNTED AND WIRED ON EVAPORATOR

TERMINALS

- -COMPONENT TERMINAL
- -TERMINAL BLOCK TERMINAL

CONDUCTORS/WIRING

- FACTORY WIRING
- - - - - WIRING BY OTHERS
- OPTIONAL FACTORY OR BY OTHERS

ALL FIELD WIRING MUST BE DONE IN COMPLIANCE WITH ALL APPLICABLE LOCAL AND NATIONAL CODES.

DIMENSIONAL DATA - 1 FAN

Inches (mm)

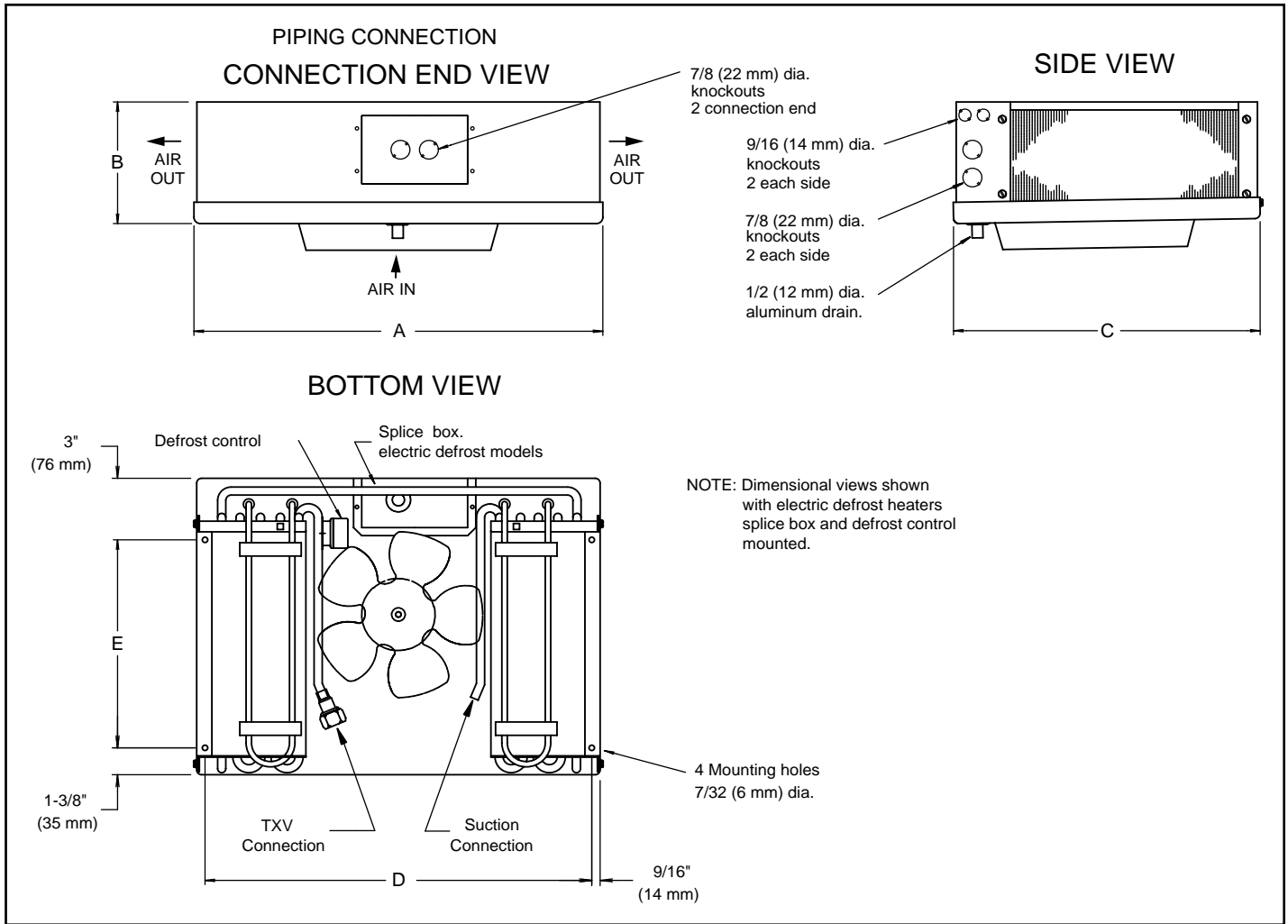

MODEL	Suc. Conn.	TXV	A		B		C		D		E		APPROX. WEIGHT	
	(ID) Sweat	Inlet Size	Inches	mm	Inches	mm	Inches	mm	Inches	mm	Inches	mm	Lbs.	Kgs
010M*	3/8	1/2" Flare	18 7/8	479	4 1/2	114	14 1/8	359	17 3/4	451	9 3/4	248	11.6	5.3
015M*	3/8	1/2" Flare	18 7/8	479	4 1/2	114	14 1/8	359	17 3/4	451	9 3/4	248	12.6	5.7
020M*	3/8	1/2" Flare	18 7/8	479	5 1/2	140	14 1/8	359	17 3/4	451	9 3/4	248	13.7	6.2
025M*	3/8	1/2" Flare	18 7/8	479	5 1/2	140	14 1/8	359	17 3/4	451	9 3/4	248	14.7	6.7
032M*	3/8	1/2" ODS	21 7/8	556	5 1/2	140	19 1/8	486	20 3/4	527	14 3/4	375	18.9	8.6
038M*	3/8	1/2" ODS	21 7/8	556	5 1/2	140	19 1/8	486	20 3/4	527	14 3/4	375	20.0	9.1
009LE	3/8	1/2" Flare	18 7/8	479	4 1/2	114	14 1/8	359	17 3/4	451	9 3/4	248	11.6	5.3
013LE	3/8	1/2" Flare	18 7/8	479	4 1/2	114	14 1/8	359	17 3/4	451	9 3/4	248	12.6	5.7
017LE	3/8	1/2" ODS	18 7/8	479	5 1/2	140	14 1/8	359	17 3/4	451	9 3/4	248	13.7	6.2
021LE	3/8	1/2" ODS	18 7/8	479	5 1/2	140	14 1/8	359	17 3/4	451	9 3/4	248	14.7	6.7
028LE	1/2	1/2" ODS	21 7/8	556	5 1/2	140	19 1/8	486	20 3/4	527	14 3/4	375	18.9	8.6
033LE	1/2	1/2" ODS	21 7/8	556	5 1/2	140	19 1/8	486	20 3/4	527	14 3/4	375	20.0	9.1

* - A (AIR DEFROST) OR E (ELECTRIC DEFROST)

DIMENSIONAL DATA - 2 & 3 FAN

Inches (mm)

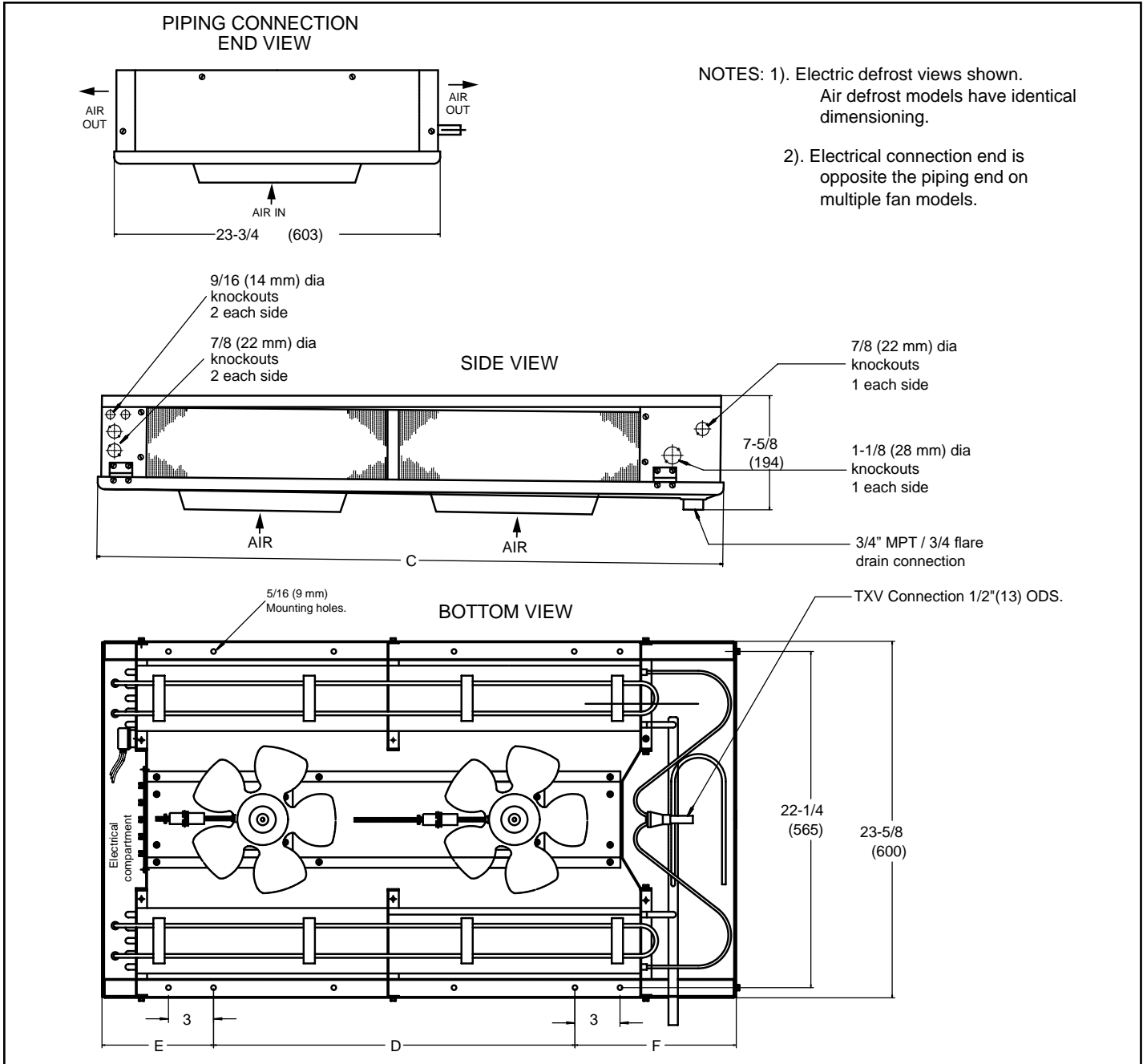

MODEL TTL	Suc. Conn.	TXV	C		D		E		F		APPROX. WEIGHT	
	(ID) Sweat	Inlet Size	Inches	mm	Inches	mm	Inches	mm	Inches	mm	Lbs.	Kgs
060M	1/2	1/2" ODS	42 3/4	1086	4 holes @ 8"	203	7 11/16	195	10 15/16	278	37.8	17.1
077M	5/8	1/2" ODS	42 3/4	1086	4 holes @ 8"	203	7 11/16	195	10 15/16	278	39.9	18.1
115M	5/8	1/2" ODS	59 1/2	1511	6 holes @ 8"	203	8	203	11 7/16	291	59.9	27.2
052LE	5/8	1/2" ODS	42 3/4	1086	4 holes @ 8"	203	7 11/16	195	10 15/16	278	37.8	17.1
066LE	5/8	1/2" ODS	42 3/4	1086	4 holes @ 8"	203	7 11/16	195	10 15/16	278	39.9	18.1
099LE	7/8	1/2" ODS	59 1/2	1511	6 holes @ 8"	203	8	203	11 7/16	291	59.9	27.2

NOZZLE SELECTIONS (FACTORY INSTALLED)

For all applications and refrigerants

Model TTL	Nozzle
010MA/ME	NA
015MA/ME	NA
020MA/ME	NA
025MA/ME	NA
032MA/ME	L-1/4
038MA/ME	L-1/3
060MA/ME	L-1/2
077MA/ME	L-3/4
115MA/ME	L-1

Model TTL	Nozzle
009LE	NA
013LE	NA
017LE	L-1/4
021LE	L-1/3
028LE	L-1/2
033LE	L-1/2
052LE	L-1
066LE	L-1
099LE	L-1 1/2

RECOMMENDED EXPANSION VALVE SELECTION MEDIUM TEMPERATURE MODELS

SPORLAN

MODEL TTL	TD	R404A	R448A R407A
		R507	R407C R22
010M	10	EGS-1/8-C	EGV-1/5-C
	15		
015M	10	EGS-1/6-C	EGV-1/5-C
	15		
020M	10	EGS-1/6-C	EGV-1/5-C
	15		
025M	10	EGS-1/6-C	EGV-1/5-C
	15		EGV-1/3-C
032M	10	SBFSE-AA-C	SBFVE-AAA-C
	15		SBFVE-AA-C
038M	10	SBFSE-AA-C	SBFVE-AAA-C
	15		SBFVE-AA-C
060M	10	SBFSE-A-C	SBFVE-AA-C
	15		
077M	10	SBFSE-A-C	SBFVE-AA-C
	15		SBFVE-A-C
115M	10	SBFSE-A-C	SBFVE-A-C
	15		

For medium temp. R-507, refrigerant designation changes from 'S' to 'P'.
For R449A, use R448A data.

ALCO

MODEL TTL	TD	R404A	R448A R407A
		R507	R407C R22
010M	10	HF-1/8-SC	HF-1/4-HC
	15		
015M	10	HF-1/8-SC	HF-1/4-HC
	15		
020M	10	HF-1/8-SC	HF-1/4-HC
	15	HF-1/4-SC	
025M	10	HF-1/4-SC	HF-1/4-HC
	15		
032M	10	HFESC-1/4-SC	HFESC-1/4-HC
	15	HFESC-1/2-SC	HFESC-1/2-HC
038M	10	HFESC-1/4-SC	HFESC-1/2-HC
	15	HFESC-1/2-SC	
060M	10	HFESC-1/2-SC	HFESC-1/2-HC
	15	HFESC-1-SC	HFESC-1-HC
077M	10	HFESC-1/2-SC	HFESC-1-HC
	15	HFESC-1-SC	
115M	10	HFESC-1-SC	HFESC-1-HC
	15	HFESC-1 1/4-SC	HFESC-1 1/2-HC

All TXV Selections based on 90-100°F liquid.
For R449A, use R448A data.

DANFOSS

MODEL TTL	TD	R404A	R448A R407A
		R507	R407C R22
010M	10	TUA-R404A-0-N	TUA-R22-0-N
	15	TUA-R404A-1-N	
015M	10	TUA-R404A-1-N	TUA-R22-0-N
	15	TUA-R404A-2-N	TUA-R22-1-N
020M	10	TUA-R404A-2-N	TUA-R22-1-N
	15	TUAE-R404A-3-N	TUAE-R22-2-N
025M	10	TUA-R404A-2-N	TUA-R22-1-N
	15	TUAE-R404A-3-N	TUAE-R22-2-N
032M	10	TUAE-R404A-3-N	TUAE-R22-2-N
	15	TUAE-R404A-4-N	TUAE-R22-3-N
038M	10	TUAE-R404A-3-N	TUAE-R22-3-N
	15	TUAE-R404A-4-N	TUAE-R22-4-N
060M	10	TUAE-R404A-5-N	TUAE-R22-4-N
	15	TUAE-R404A-6-N	TUAE-R22-5-N
077M	10	TUAE-R404A-5-N	TUAE-R22-5-N
	15	TUAE-R404A-6-N	TUAE-R22-6-N
115M	10	TUAE-R404A-6-N	TUAE-R22-6-N
	15	TUAE-R404A-8-N	TUAE-R22-7-N

For R449A, use R448A data.

RECOMMENDED EXPANSION VALVE SELECTION - MEDIUM TEMPERATURE MODELS

SPORLAN - R407A R448A

MODEL TTL		009L		013L		017L		021L		028L	
		BTUH	VALVE #	BTUH	VALVE #	BTUH	VALVE #	BTUH	VALVE #	BTUH	VALVE #
EVAP TEMP. °F	0	865	EGV-1/5-C	1,273	EGV-1/5-C	1,729	EGVE-1/5-C	2,138	SBFVE-AAA-C	2,850	SBFVE-AAA-C
	-10	836	EGV-1/5-Z	1,235	EGV-1/5-Z	1,682	SBFVE-AAA-Z	2,071	SBFVE-AAA-Z	2,765	SBFVE-AAA-Z
	-15	827		1,216		1,644		2,033		2,717	
	-20	808		1,188		1,615		1,995		2,660	
MODEL TTL		033L		052L		066L		099L			
		BTUH	VALVE #	BTUH	VALVE	BTUH	VALVE #	BTUH	VALVE #		
EVAP TEMP. °F	0	3,354	SBFVE-AAA-C	5,282	SBFVE-AA-C	6,707	SBFVE-AA-C	10,061	SBFVE-A-C		
	-10	3,259	SBFVE-AA-Z	5,140	SBFVE-AA-Z	6,517	SBFVE-AA-Z	9,785	SBFVE-A-Z		
	-15	3,202		5,035		6,394		9,595			
	-20	3,135		4,940		6,270		9,405			

Selections based on 90-100°F liquid.

For R407A valves operating below 0F, the pressure limiting charge 'ZP40' may be substituted for the 'Z' charge.

R407A derated by .95 factor

For R449A, use R448A data.

SPORLAN - R404A

MODEL TTL		009L		013L		017L		021L		028L	
		BTUH	VALVE #	BTUH	VALVE #	BTUH	VALVE #	BTUH	VALVE #	BTUH	VALVE #
EVAP TEMP. °F	0	910	EGS-1/8-C	1,340	EGS-1/8-C	1,820	SBFSE-AAA-C	2,250	SBFSE-AAA-C	3,000	SBFSE-AA-C
	-10	880	EGS-1/8-Z	1,300	EGS-1/8-Z	1,770	SBFSE-AAA-Z	2,180	SBFSE-AAA-Z	2,910	SBFSE-AA-Z
	-15	870		1,280		1,730		2,140		2,860	
	-20	850		1,250		1,700		2,100		2,800	
MODEL TTL		033L		052L		066L		099L			
		BTUH	VALVE #	BTUH	VALVE	BTUH	VALVE #	BTUH	VALVE #		
EVAP TEMP. °F	0	3,530	SBFSE-AA-C	5,560	SBFSE-AA-C	7,060	SBFSE-A-C	10,590	SBFSE-A-C		
	-10	3,430	SBFSE-AA-Z	5,410	SBFSE-A-Z	6,860	SBFSE-A-Z	10,300	SBFSE-A-Z		
	-15	3,370		5,300		6,730		10,100			
	-20	3,300		5,200		6,600		9,900			

Selections based on 90-100°F liquid.

For medium temp. R-507, refrigerant designation changes from 'S' to 'P'.

For R404A/R507 valves operating below 0F, the pressure limiting charge 'ZP' may be substituted for the 'Z' charge.

For R449A, use R448A data.

INSPECTION

Careful inspection of all parts when received for loss or damage in transit is very important -

Remember, you, the consignee, must make any claim necessary against the transportation company. Shipping damage or missing parts, when discovered at the outset, will prevent later unnecessary and costly delays.

Electrical characteristics should also be checked at this time to ensure that they are as ordered.

APPLICATION

Two-Way evaporators are designed for use in coolers and freezers such as reach in boxes, display cases, back bars, walk-in rooms and any other cooler applications where a low velocity, uniform air flow is required. The compact and low height unit provides maximum useable product storage space.

At room temperatures above 34°F (**1.1°C**) and evaporating temperatures no lower than 27°F (**-2.8°C**) the air flowing through the coil will accomplish the defrost (Air Defrost).

At room temperatures 34°F and below (to -10°F) positive defrosting is required (Electric defrost).

These will require the use of:

1. *Time Clock* (to initiate and terminate the defrost cycle),
2. *Defrost termination thermostat* (to prevent unnecessary prolonged heating and steaming of the coil once all the frost and ice has melted). And if a freezer,
3. *Fan delay thermostat* (to prevent evaporator fans starting up right away and blowing water on to the fan blades, guards and floor).

This evaporator coil must not be exposed to any abnormal environments (acidic or caustic) that can result in coil corrosion and leaks. Consult factory for optional baked on phenolic protective coatings. These evaporators are for use primarily on R448A/R407A/R407C/R404A/R507/R22 and R134a refrigerants and their approved alternatives / replacements.

INSTALLATION

The installation and start up of evaporators should only be performed by qualified refrigeration mechanics. This equipment should be installed in accordance with all applicable codes, ordinances, and local by-laws.

LOCATION

The evaporator is designed to be mounted to the ceiling of the box or cabinet. Refrigeration piping and electrical connections are routed to the rear sides (through the knock-outs). The unit must be mounted to a level ceiling to ensure complete drainage from the condensate pan to the drain fitting. Refer to the dimensional drawings for the drain fitting and mounting location details.

On freezer applications it is important that warm, humid infiltrated air is **not drawn directly towards the evaporator**. Keeping the evaporator away from the door, using strip curtains, and using door switches to lock out and de-energize the liquid solenoid valve are all effective methods to minimize any unnecessary frost build-up of the fan guard. (Air enters the fan and discharges out each side of the coil).

TXV SELECTION (thermostatic expansion valve)

For normal operating conditions refer to the TXV selection chart. When selecting valves ensure they are sized to meet the capacity at the actual evaporating temperature, liquid temperature and operating TD of the system. All these conditions can greatly affect the size and selection. Consult the factory or valve manufacturer for assistance. All models that use a distributor (larger models) must use a nozzle. Smaller models do not have distributors or nozzles.

The TXV superheat setting should NOT be initially adjusted. After the room has reached or is close to the required operating temperature the TXV superheat should then be checked and only adjusted if necessary. Refer to Section on SYSTEM CHECK.

To avoid overheating the valve or distributor wrap a wet cloth around the valve diaphragm and body.

MOUNTING

Mounting brackets with 7/32 - 5/16" diameter holes are provided for flush mounting to the ceiling. Ensure the evaporator is located correctly with the air flowing in the two desired directions. Avoid discharging the air directly on to glass doors or door openings.

After mounting the coil **check the slope** of the drain pan with a level. If the ceiling is not level the drain pan slope may not be correct which can result in defrosting (ice-up) problems.

DRAIN LINE

The drain line should be run from the drain connection, sloping at least 4" vertical drop for every foot of horizontal distance . A trap outside the room will allow proper draining throughout the line. Connection should be made to proper drainage facilities that comply with local codes and regulations.

In freezers, to prevent drain line freeze up problems, the line must be heated and insulated. A heat input of 20 W per foot in a 0°F room and 30 W per foot in a -20°F room is usually satisfactory. Once the line has been completed , double check the slope in the drain pan to ensure proper drainage (prevention of ice build-up on pan).

PIPING

Refrigerant line sizes are important and are not necessarily the same size as the connections at the condensing unit or evaporator. If in doubt refer to a recognized source. (Manufacturer's Engineering Manual, Ashrae Manuals, etc.)

WIRING

Wire system in accordance with local codes and regulations. A 36" cord is provided for single fan air defrost models (AD). Multiple fans have a junction terminal box for conduit connections.

When fan delay thermostats are installed the fans may not start up until the coil temperature reaches approximately 26°F. On initial start up it may be necessary to bypass (jumper) this control temporarily until the coil is cold enough.

SYSTEM CHECK

Before Start Up:

1. Ensure wiring is in accordance with codes.
2. Refrigerant lines are properly sized and routed.
3. Thorough leak check, evacuation and dehydration has been performed.
4. Drain line has been checked for free flow.

After Start Up:

1. Fan has been checked for correct air flow and no obstructions.
2. Expansion valve superheat has been checked for proper operation. (Superheat of the coil should be around 5 to 6°F for a 10°F TD.)

MAINTENANCE

The unit should be periodically inspected for any dirt or build up on the fin surface and cleaned if necessary with a soft whisk or brush.

The fan motor is permanently lubricated and should not require service.

PROJECT INFORMATION

System	
Model Number	Date of Start-Up
Serial Number	Service Contractor
Refrigerant	Phone
Electrical Supply	E-Mail



PRODUCT SUPPORT

web: t-rp.com/ttl
email: evaps@t-rp.com
call: 1-844-893-3222 x520



TROUBLESHOOTING

email: troubleshooting@t-rp.com
call: 1-844-893-3222 x529



SERVICE PARTS

web: t-rp.com/parts
email: parts@t-rp.com
call: 1-844-893-3222 x501



WARRANTY

web: t-rp.com/warranty
email: warranty@t-rp.com
call: 1-844-893-3222 ext. 501



ORDERS

email: orders@t-rp.com
call: 1-844-893-3222 x501



SHIPPING

email: shipping@t-rp.com
call: 1-844-893-3222 x503

“AS BUILT” SERVICE PARTS LIST

Service Parts List
Label
To Be Attached
HERE



**NATIONAL REFRIGERATION &
AIR CONDITIONING CANADA CORP.**
159 Roy Blvd.
Brantford Ontario Canada N3R 7K1
PHONE: (519) 751-0444 800-463-9517
FAX (519) 753-1140 www.t-rp.com



Due to the manufacturer's policy of continuous product improvement, we reserve the right to make changes without notice.